

Rolls

FLOODED DEEP CYCLE BATTERIES

S-330



CONTAINER:	Polypropylene
COVER:	Polypropylene
TERMINALS:	Universal molded post
HANDLES:	No handles

WEIGHT DRY:	27 kg	59 Lbs.
WEIGHT WET:	36 kg	79 Lbs.
LENGTH:	259 mm	10 3/16 Inches
WIDTH:	181 mm	7 1/8 Inches
HEIGHT:	290 mm	11 2/5 Inches

6 VOLTS

PLATE HEIGHT:	180 mm	7.100 Inches
PLATE WIDTH:	159 mm	6.250 Inches
THICKNESS (POSITIVE):	2.79 mm	0.110 Inches
THICKNESS (NEGATIVE):	2.24 mm	0.088 Inches



CELLS:	19 Plates/Cell	3 Cell
SEPARATOR THICKNESS:	2 mm	0.081 Inches
GLASS MAT INSULATION:	1 mm	0.02 Inches
ELECTROLYTE RESERVE: ABOVE PLATES	63 mm	1.75 Inches

COLD CRANK AMPS (CCA):	0°F / -17.8°C	758
MARINE CRANK AMPS (MCA):	32°F / 0°C	948
RESERVE CAPACITY (RC @ 25A):		336 Minutes

CAPACITY **250 AH**

HOURLY RATE:	SPECIFIC GRAVITY	CAPACITY / AMP HOUR	CURRENT / AMPS
@ 100 HOUR RATE	1.280	333	3.33
@ 72 HOUR RATE	1.280	315	4.38
@ 50 HOUR RATE	1.280	298	5.95
@ 24 HOUR RATE	1.280	258	10.73
@ 20 HOUR RATE	1.280	250	12.50
@ 15 HOUR RATE	1.280	235	15.67
@ 12 HOUR RATE	1.280	223	18.54
@ 10 HOUR RATE	1.280	213	21.25
@ 8 HOUR RATE	1.280	200	25.00
@ 6 HOUR RATE	1.280	185	30.83
@ 5 HOUR RATE	1.280	175	35.00
@ 4 HOUR RATE	1.280	163	40.63
@ 3 HOUR RATE	1.280	148	49.17
@ 2 HOUR RATE	1.280	128	63.75
@ 1 HOUR RATE	1.280	90	90.00

CYCLE LIFE VS. DEPTH OF DISCHARGE

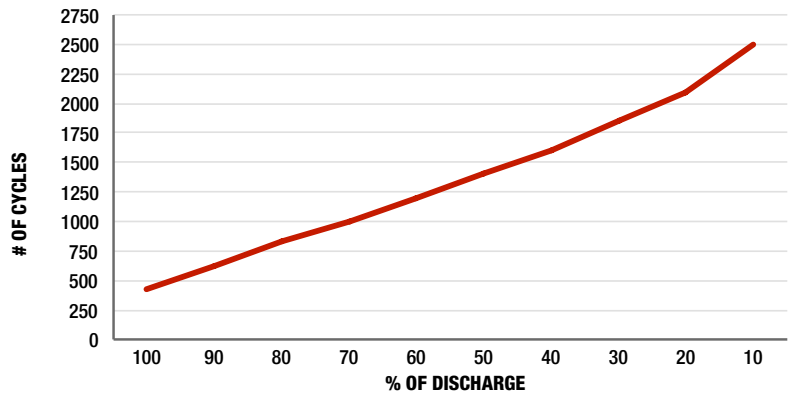

VOLTAGE VS. DEPTH OF DISCHARGE

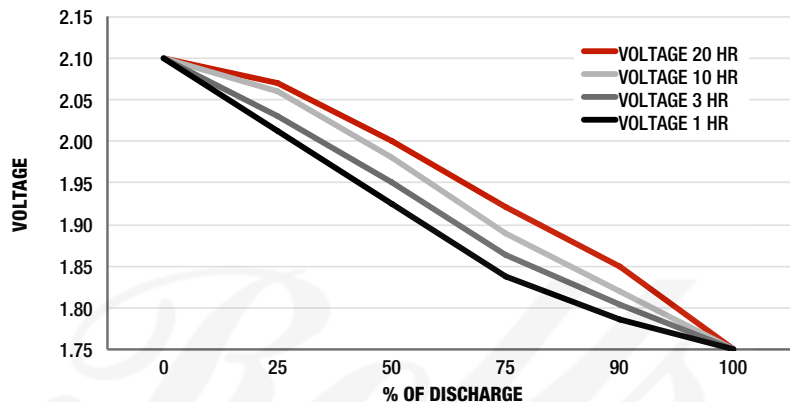



SAI GLOBAL
ISO 9001
Quality

PART NUMBER: S-330

WEIGHT WET: 79 LB / 36 KG

WEIGHT DRY: 59 LB / 29 KG

CAPACITY 250 AH 20HR RATE

VOLTAGE: 6 V

OVERALL DIMENSIONS: 10 $\frac{3}{16}$ " X 7 $\frac{1}{8}$ " X 11 $\frac{2}{5}$ "

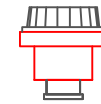
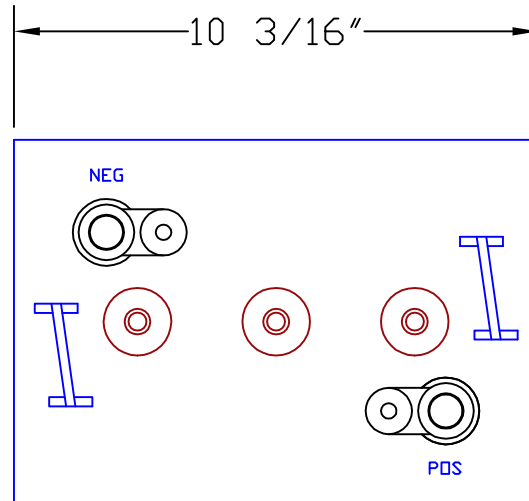

MAX HEIGHT WITH
OPTIONAL HYDROCAPS 12"

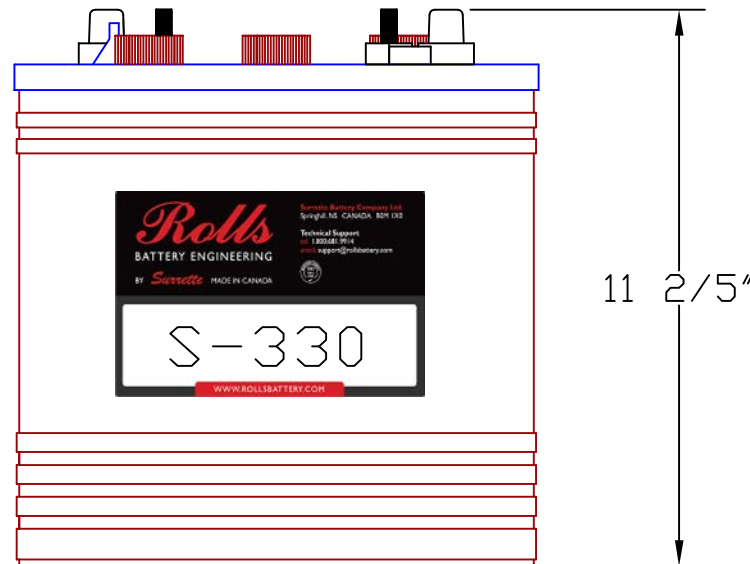
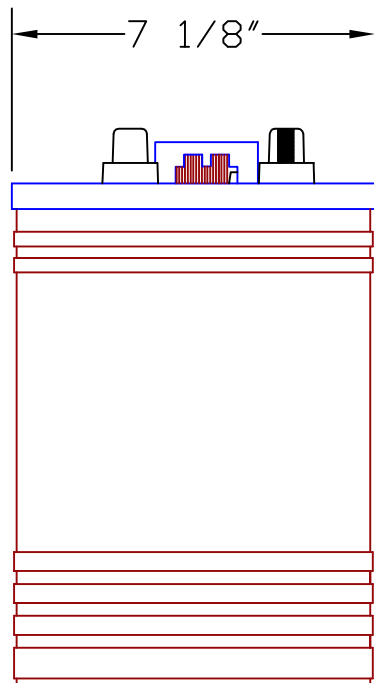

Rolls
BATTERY ENGINEERING

TITLE:
S-330

DESCRIPTION:
6V DEEP CYCLE SERIES 4000

CONTACT INFO:
WEB: WWW.ROLLSBATTERY.COM
E-MAIL: SALES@ROLLSBATTERY.COM
PHONE: 1-800-681-9914

SCALE: 1" = 4" JPEG:
8.5" X 11" NOT TO SCALE

Drawn by: P. FERRON Approved By: JD SURRETTE

DATE: MAY-2013 REVISION 0

DRAWING NO.: S330.dwg